



# Downlight DN060B

## DN060B LED8S/840 PSU WH

LED Module, system flux 800 lm - 840 neutral white - Power supply unit - White

The LEDINAIRE range contains a selection of popular off-the-shelf LED luminaires that come with the high Philips quality levels at a competitive price. Reliable, energy-efficient and affordable – just what you need.

### Product data

General Information	
Lamp family code	LED8S [ LED Module, system flux 800 lm]
Beam angle of light source	90 x 90 °
Light source color	840 neutral white
Light source replaceable	No
Number of gear units	1 unit
Gear	-
Driver/power unit/transformer	Power supply unit
Driver included	Yes
Optic type	Symmetrical
Luminaire light beam spread	10°
Connection	Push-in connector 2-pole
Cable	-
Protection class IEC	Safety class I
Glow-wire test	Temperature 650 °C, duration 5 s
Flammability mark	-
CE mark	CE mark
ENEC mark	-
Warranty period	3 years

Constant light output	No
Number of products on MCB of 16 A type B	48
RoHS mark	RoHS mark

Operating and Electrical	
Input Voltage	220-240 V
Input Frequency	50 to 60 Hz
Control signal voltage	-
Inrush current	11.3 A
Inrush time	0.001 ms
Power Factor (Min)	0.9

Controls and Dimming	
Dimmable	No

Mechanical and Housing	
Housing Material	Metal/Plastic
Reflector material	Steel
Optic material	Polycarbonate

## Downlight DN060B

Optical cover/lens material	Polycarbonate
Fixation material	Stainless steel
Optical cover/lens finish	Opal
Overall height	100 mm
Overall diameter	173 mm

### Approval and Application

Ingress protection code	IP20 [ Finger-protected]
Mech. impact protection code	IK02 [ 0.2 J standard]

### Initial Performance (IEC Compliant)

Initial luminous flux (system flux)	800 lm
Luminous flux tolerance	+/-10%
Initial LED luminaire efficacy	89 lm/W
Init. Corr. Color Temperature	4000 K
Init. Color Rendering Index	>80
Initial chromaticy	(0.38, 0.38) SDCM <5
Initial input power	9 W
Power consumption tolerance	+/-10%

### Over Time Performance (IEC Compliant)

Driver failure rate at 5000 h	1.50 %
-------------------------------	--------

Median useful life L70B50	30000 h
Median useful life L80B50	20000 h
Median useful life L90B50	10000 h

### Application Conditions

Ambient temperature range	0 to +35 °C
Suitable for random switching	Not applicable

### Product Data

Full product code	871016330664399
Order product name	DN060B LED8S/840 PSU WH
EAN/UPC - Product	8710163306643
Order code	911401532231
Numerator - Quantity Per Pack	1
Numerator - Packs per outer box	12
Material Nr. (12NC)	911401532231
Net Weight (Piece)	0.350 kg

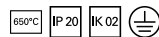

## Dimensional drawing

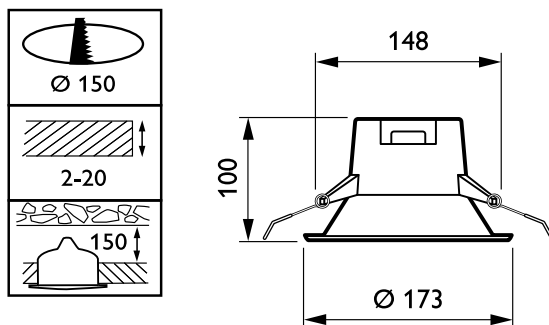

SmartBright LED DN060B-DN063B

