

JC71276

## Skytile 3000 IP44 LED Panel & Driver 600 x 600 28W 4700K

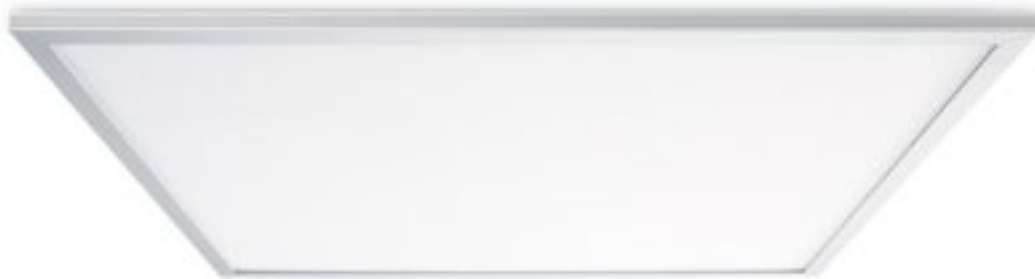

### General Information

<b>Product Group</b>	LED Recessed
<b>Product Range</b>	Skytile
<b>Product Weight</b>	4.8kg
<b>Finishes Available</b>	Aluminium extruded frame c/w opal diffuser
<b>Overall Dimensions</b>	595 x 595 x 9.8 mm
<b>Recommended Product Location</b>	indoor use only, T grid ceiling systems
<b>Minimum Void Requirement</b>	150mm
<b>Method Of Fix</b>	sits in 15mm and 25mm ceiling grid system
<b>Cut Out Ø</b>	600 x 600 mm
<b>Ingress Protection (IP)</b>	IP44
<b>Suitable For Zones</b>	Outside zone 1
<b>Recommended Fire Hood</b>	JC93009
<b>Luminaire Accessories</b>	Skytile surface mount tray(JC71262) Suspension kit (JC71611)
<b>Suspension Kit Safe Working Load</b>	20kg

#### JCC Lighting

Innovation Centre, Beeding Close, Southern Cross  
Trading Estate, Bognor Regis, West Sussex, PO22 9TS  
Company Registration Number: 03044848 | VAT Number: 918544112  
T: 01243 838999 | F: 01243 838998 | [sales@jcc.co.uk](mailto:sales@jcc.co.uk) | [www.jcc.co.uk](http://www.jcc.co.uk)

## Electrical

<b>Input Voltage (V)</b>	220-240V~
<b>Secondary Running Current</b>	700mA
<b>Operating Frequency (Hz)</b>	50/60Hz
<b>CC or CV</b>	CC
<b>Sec - Voltage (V)</b>	30-50VDC
<b>Class</b>	Class II, double insulated
<b>Output Voltage (V)</b>	<54VDC
<b>EMC Compliant (EN55015)</b>	Yes
<b>Power Factor Correction</b>	0.95
<b>Input Electrical Connections</b>	Live(brown)Neutral(blue)
<b>Dimmable</b>	No

## Thermals

<b>Room Ambient Temperature Not To Exceed</b>	26°C
<b>Room Ambient Temperature</b>	25°C
<b>Max Driver/Ballast Ambient Temp.</b>	from -20 to 50°C
<b>Thermal Cut Out</b>	Yes, auto reset
<b>Insulation Coverage</b>	do not cover
<b>Minimum Free Air Space</b>	100mm above and 50mm to sides
<b>Minimum Void Requirement</b>	150mm

## Performance Data

<b>Energy Rating</b>	A+
<b>Lumen Output</b>	3000

### JCC Lighting

Innovation Centre, Beeding Close, Southern Cross  
Trading Estate, Bognor Regis, West Sussex, PO22 9TS  
Company Registration Number: 03044848 | VAT Number: 918544112  
T: 01243 838999 | F: 01243 838998 | [sales@jcc.co.uk](mailto:sales@jcc.co.uk) | [www.jcc.co.uk](http://www.jcc.co.uk)

<b>Lumens Per Circuit Watt</b>	107 LpcW
<b>LED Life (Hours)</b>	40,000
<b>CRI: Ra</b>	80
<b>Colour Temperature (K)</b>	4700
<b>LOR (Light Output Ratio) %</b>	100%
<b>Photometry Available</b>	Yes

## Construction

<b>Main Chassis</b>	Mild steel back plate
<b>Diffuser</b>	Opal polycarbonate
<b>Lens</b>	Clear acrylic
<b>Heat Sink</b>	extruded aluminium
<b>Driver Housing</b>	polycarbonate

## Packaging

<b>Luminaire Carton Dimensions</b>	655 x 718 x 48 mm
<b>Quantity Per Outer Carton</b>	4
<b>Bar Code EAN Number</b>	5052544031601
<b>Packaged Weight</b>	5.375kg

## Standards & Approvals

<b>Manufactured In Accordance To</b>	BS EN 60598-2-1, 2-2
<b>CE Marked</b>	Yes
<b>Batch Coded</b>	yes
<b>WEEE Symbol</b>	yes
<b>Certificate Of Conformity</b>	Available on request

### JCC Lighting

Innovation Centre, Beeding Close, Southern Cross  
Trading Estate, Bognor Regis, West Sussex, PO22 9TS  
Company Registration Number: 03044848 | VAT Number: 918544112  
T: 01243 838999 | F: 01243 838998 | [sales@jcc.co.uk](mailto:sales@jcc.co.uk) | [www.jcc.co.uk](http://www.jcc.co.uk)

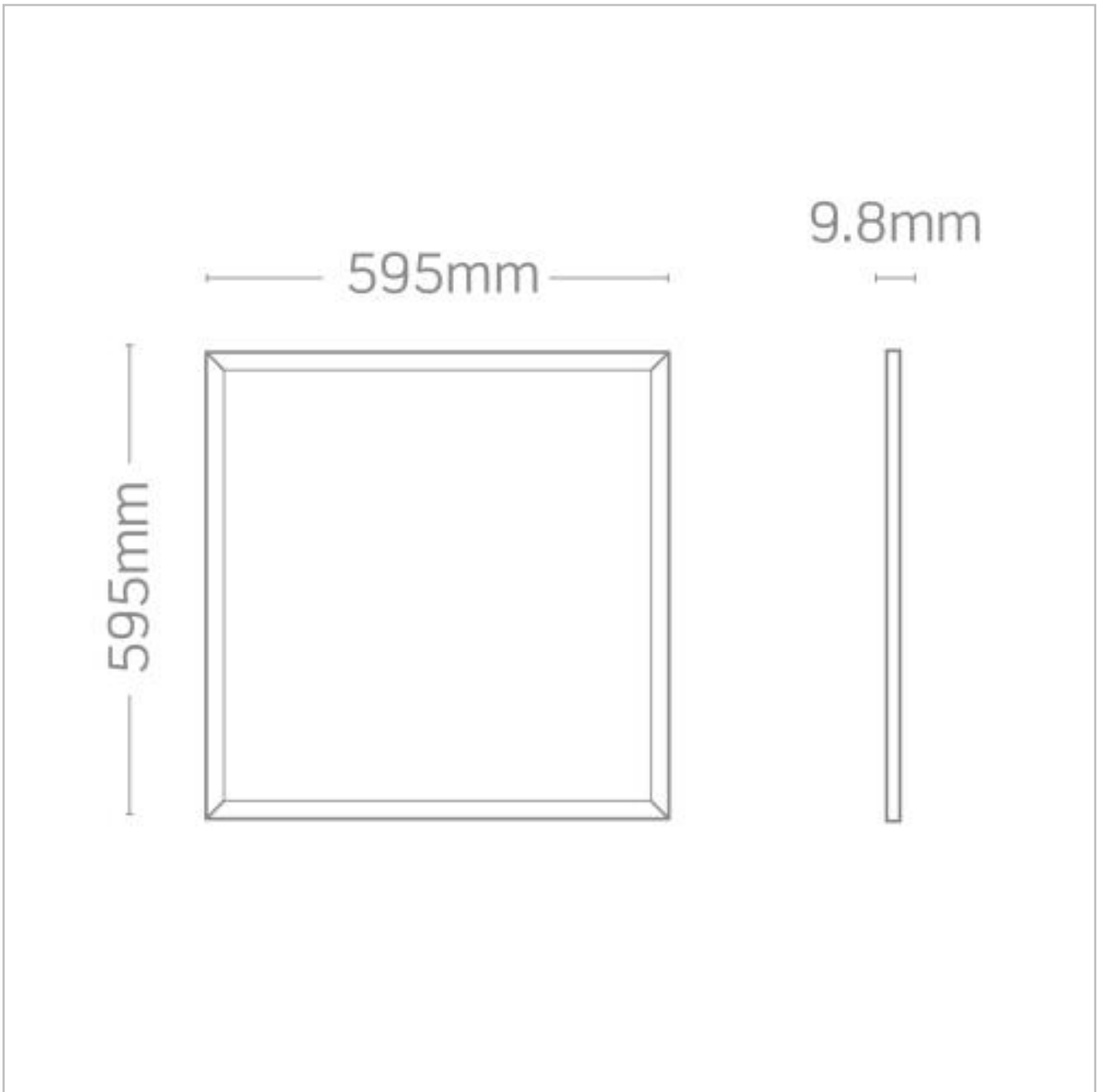

Datasheet generated from <http://www.electrika.cloud> on 30 November 2017 17:18:25

**JCC Lighting**

Innovation Centre, Beeding Close, Southern Cross  
Trading Estate, Bognor Regis, West Sussex, PO22 9TS  
Company Registration Number: 03044848 | VAT Number: 918544112  
T: 01243 838999 | F: 01243 838998 | [sales@jcc.co.uk](mailto:sales@jcc.co.uk) | [www.jcc.co.uk](http://www.jcc.co.uk)

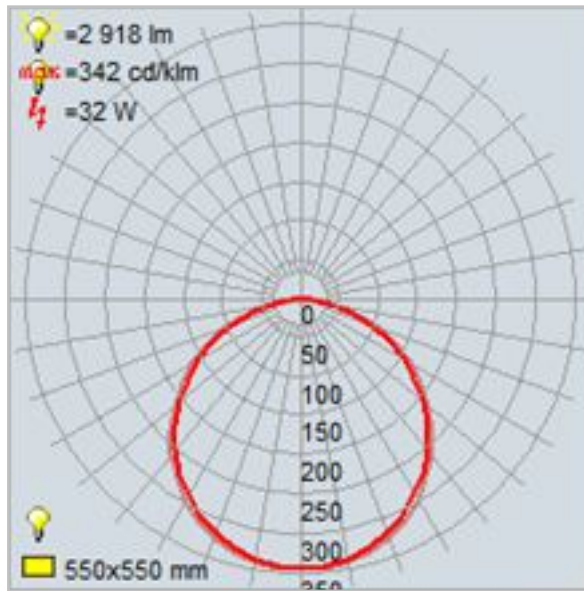

---

### JCC Lighting

Innovation Centre, Beeding Close, Southern Cross

Trading Estate, Bognor Regis, West Sussex, PO22 9TS

Company Registration Number: 03044848 | VAT Number: 918544112

T: 01243 838999 | F: 01243 838998 | [sales@jcc.co.uk](mailto:sales@jcc.co.uk) | [www.jcc.co.uk](http://www.jcc.co.uk)