

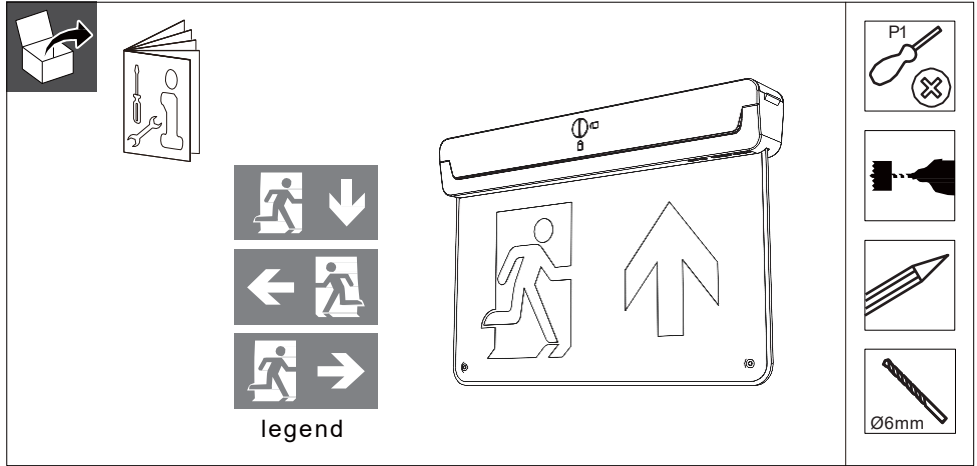

ECOLINK

ECO-E3/MT-EX-BL



	Test	CCT (K)	Lumen (lm)	P (W)	
ECOLINK EM BLADE EXIT SIGN UP.3HR MANUAL	manual	6500	23	3	0.46
ECOLINK LEGEND EM BLADE LEFT/RIGHT					
ECOLINK LEGEND EM BLADE DOWN					

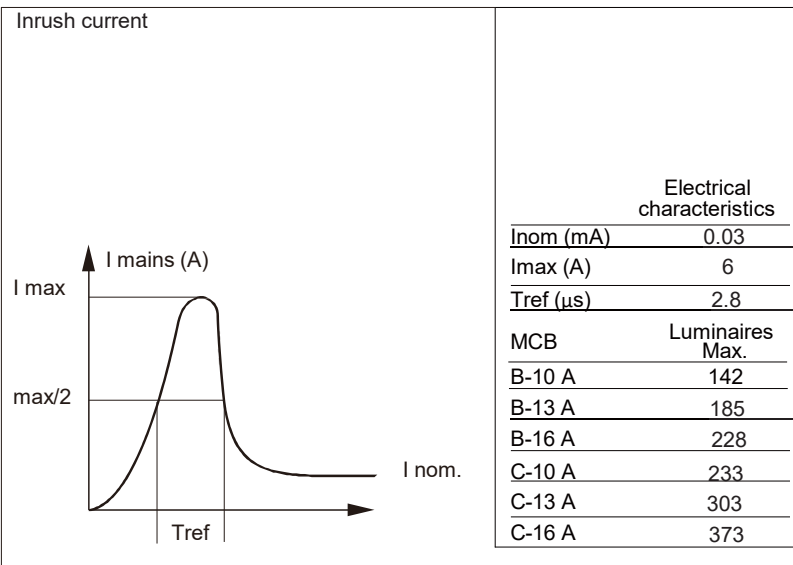
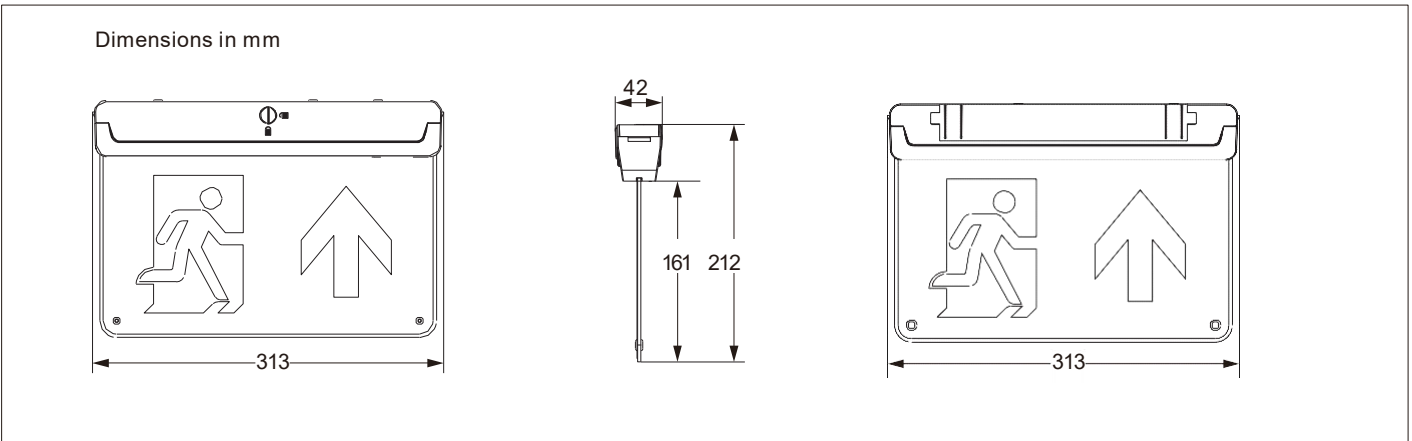

ATTENTION
OBSERVE PRECAUTIONS
FOR HANDLING
ELECTROSTATIC
SENSITIVE

- The luminaire shall be installed by a qualified electrician and wired in accordance with the latest IEE electrical regulations or the national requirements.
- When the light source reaches its end of life the whole luminaire shall be replaced.
- Clean with dry cloth.
- Philips Lighting warranty is applicable only if the indicated drivers are used.

Ceiling Mounting

1 ALWAYS SWITCH OFF THE MAINS SUPPLY BEFORE INSTALLATION OR SERVICING

2

3 Knock hole removal

4

Ceiling

Drill hole $\varnothing 6\text{mm} \times 2$

Cable grommet

28 9 2x0.75-1.5mm² max.

L Brown

N Blue

Neutral Blue

Live Brown

$\varnothing 4-8\text{mm}$

For continuity of termination of CPC

5 Connect power supply to converter

Connect battery to converter

6 Maintained

Non-Maintained

7

8 As there's no screw fixing for front cover but clip-on, could be no need torque value

9 Test button

10 SWITCH ON THE MAINS SUPPLY AFTER INSTALLATION OR SERVICING

Wall Mounting

ALWAYS SWITCH OFF THE MAINS SUPPLY BEFORE INSTALLATION OR SERVICING

1

2

3

4

Drill hole $\varnothing 6\text{mm} \times 2$

Knock holl removal

Wall

Wall

x4

x4

5

Cable grommet

28 9 2x0.75-1.5mm² max.

(L) Brown

(N) Blue

$\varnothing 4-8\text{mm}$

Neutral — Blue

Live — Brown

For continuity of termination of CPC

6

Connect power supply to converter

Connect battery to converter

7

Maintained

Non-Maintained

8

9

As there's no screw fixing for front cover but clip-on, could be no need torque value

10

Test button

11

SWITCH ON THE MAINS SUPPLY AFTER INSTALLATION OR SERVICING

Pictogram Replacement

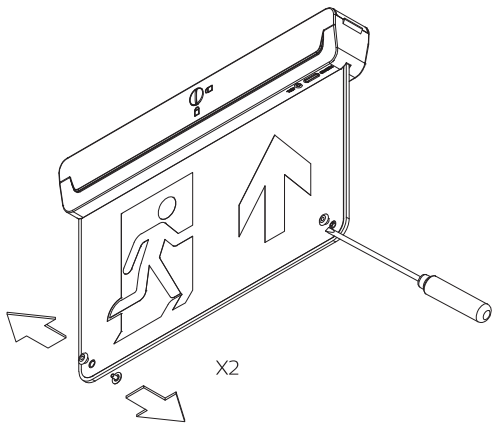

1

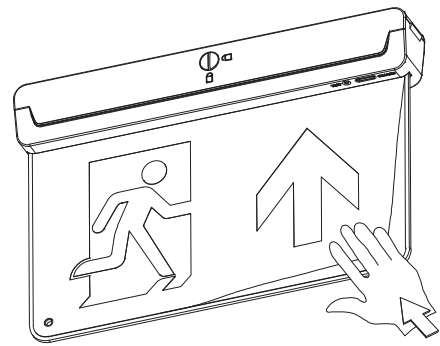

2

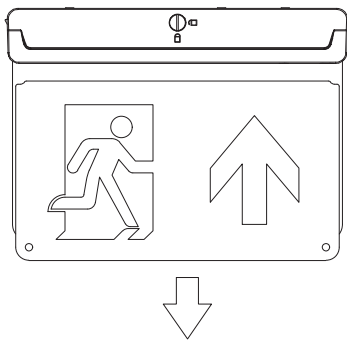

3

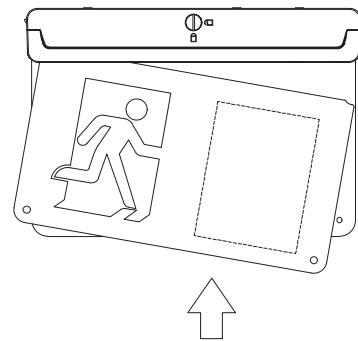

4

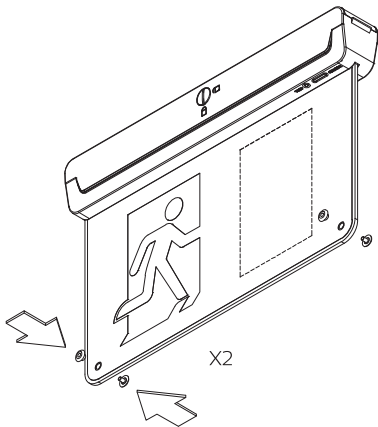

5

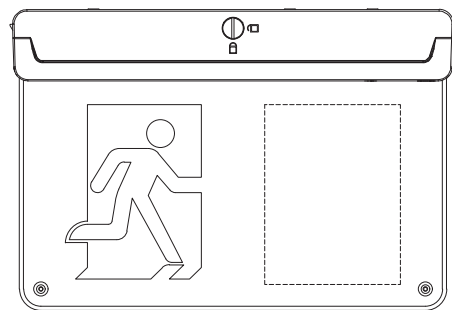

6

Note: 1. Except blank pictogram, please remove the protective film of pictogram when pictogram replacement.
2. Blank pictogram has two color surfaces, the white surface towards outside when pictogram replacement.

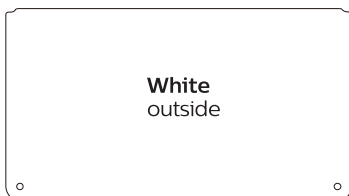

Battery replacement

LiFePO₄ -18650-1100mAh-3.2V

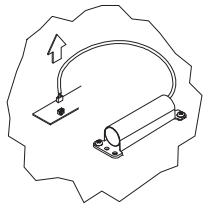

Disconnect battery to converter

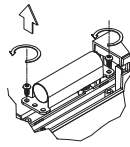

Remove the battery

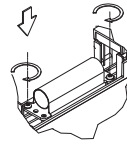

Replace the battery

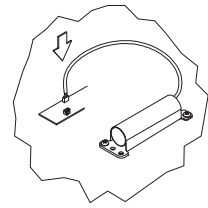

Connect battery to converter

Luminous Intensity Distribution

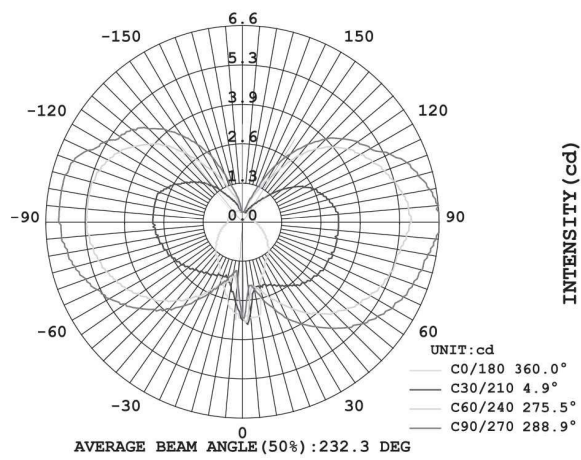

Viewing Distance

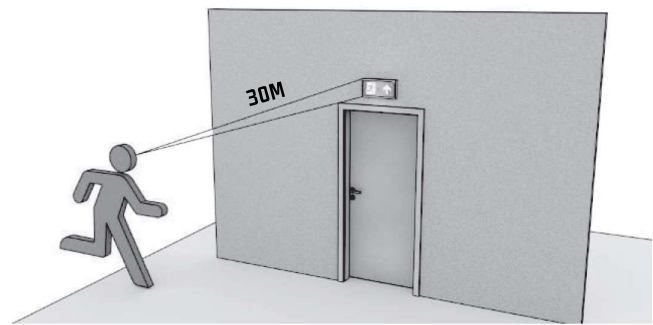



1. For indoor use only.
2. The luminaire complies with IEC60598-1IEC 60598-2-22.
The luminaire must be installed by a qualified electrician and wired in accordance with the latest IEE Electrical regulations or the national requirements.
3. Turn off the power supply before checking, installation, maintenance or moving.
4. Do not switch on before complete installation.
5. Batteries shall only be replaced by the manufacturer or his service agent or a similar qualified person.
6. Batteries should be replaced when the luminaire no longer meets the 3 hours duration performance.
7. Product mains surge immunity is 0.5/1KV (diff. / comm. mode). To prevent excessive currents and voltages from damaging the device, make sure that the power supply input is equipped with additional protection devices such as surge protectors. For any questions regarding the product's surge protection, please consult the manufacturer's professional.



Please inform yourself about the local waste disposal, separation and collection system for electrical and electronic products and packaging. Please act according to your local rules and do not dispose your old product and packaging with your normal household waste. The correct disposal of the packaging, your product and/or batteries will help prevent potential negative consequences for the environment and human health. Batteries should be disposed separately from the municipal waste stream via designated collection facilities. When disposing a product that contains non-user replaceable batteries, the non-user replaceable batteries shall be removed by a professional.

Testing Record

Product: _____ Location: _____ Installation Date: _____

Month	Functional/Duration	Year 1	Year 2	Year 3	Year 4	Year 5
1						
2						
3						
4						
5						
6						
7						
8						
9						
10						
11						
12						