

ECOLINK

ECO-E3/MT-TW-SP

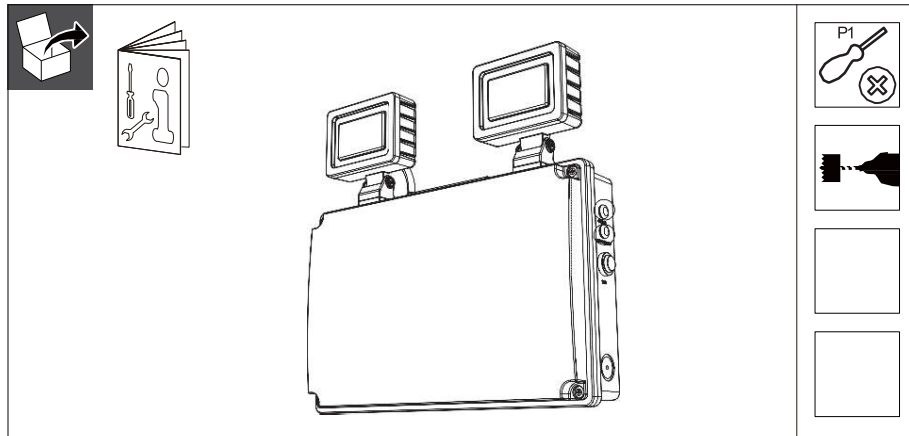

Test	CCT (K)	Lumen (lm)	P (W)	Icon
ECOLINK EM TWIN SPOT 3HR MANUAL IP65	6500	1000	8	

Dimensions in mm

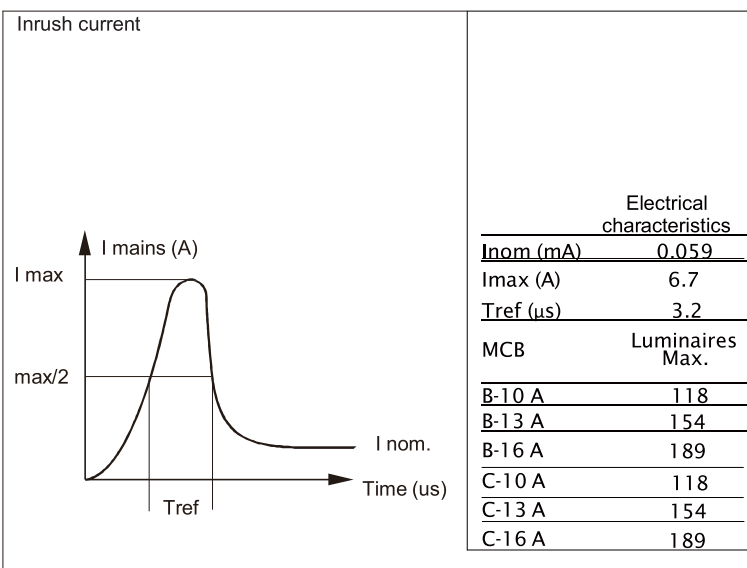
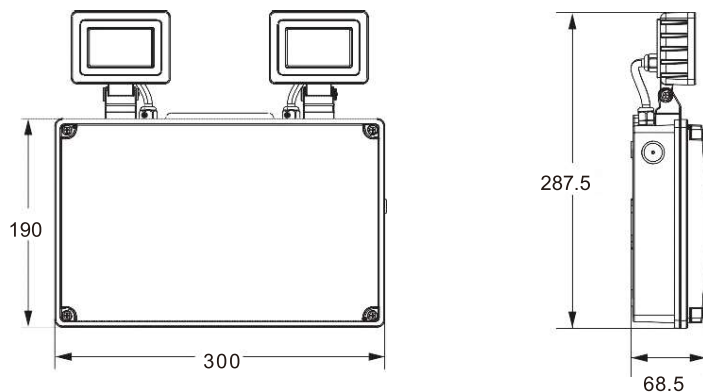

ATTENTION
OBSERVE PRECAUTIONS
FOR HANDLING
ELECTROSTATIC
SENSITIVE
DEVICES

- The luminaire shall be installed by a qualified electrician and wired in accordance with the latest IEE electrical regulations or the national requirements.
- When the light source reaches its end of life the whole luminaire shall be replaced.
- Clean with dry cloth.
- Philips Lighting warranty is applicable only if the indicated drivers are used.

ALWAYS SWITCH OFF THE
MAINS SUPPLY BEFORE
INSTALLATION OR SERVICING

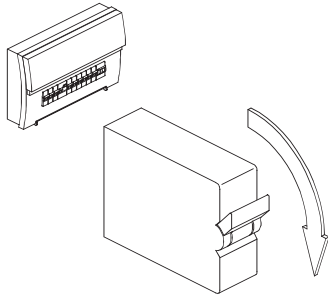

1

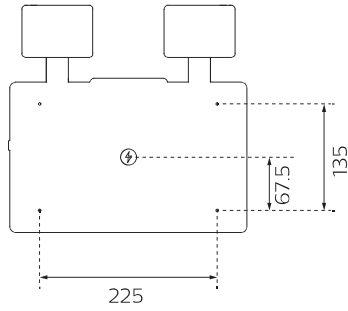

2

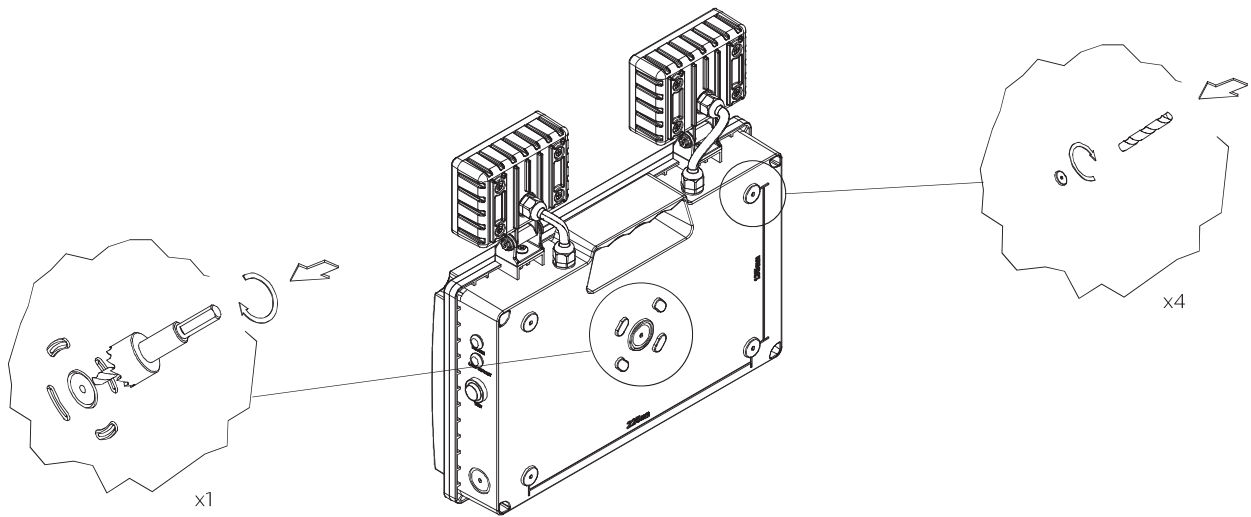
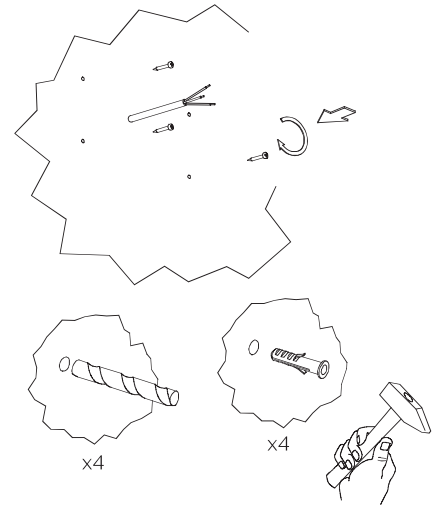

3

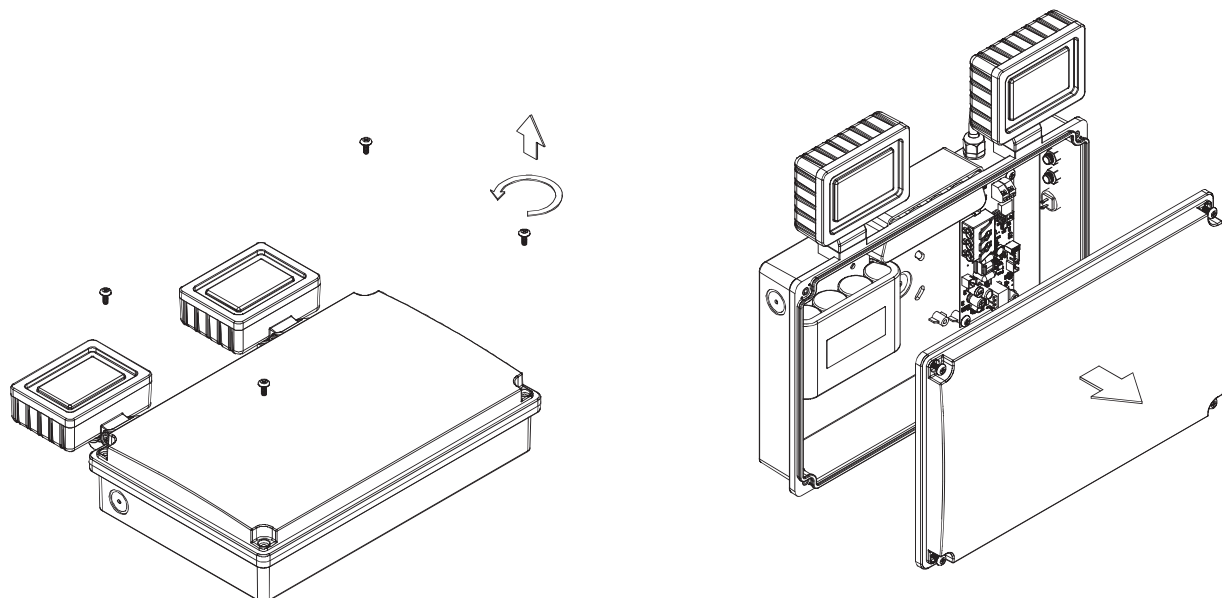

4

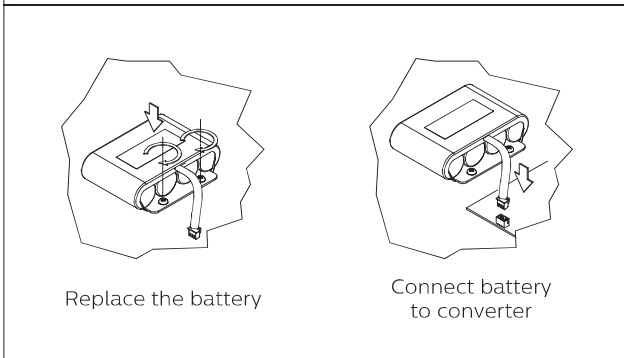
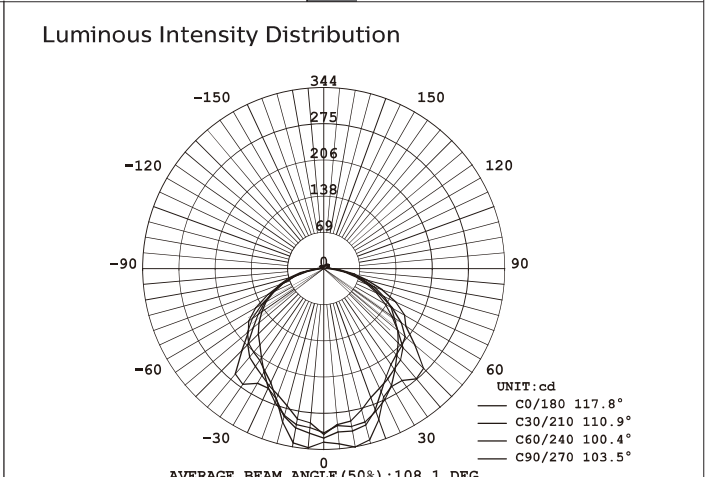
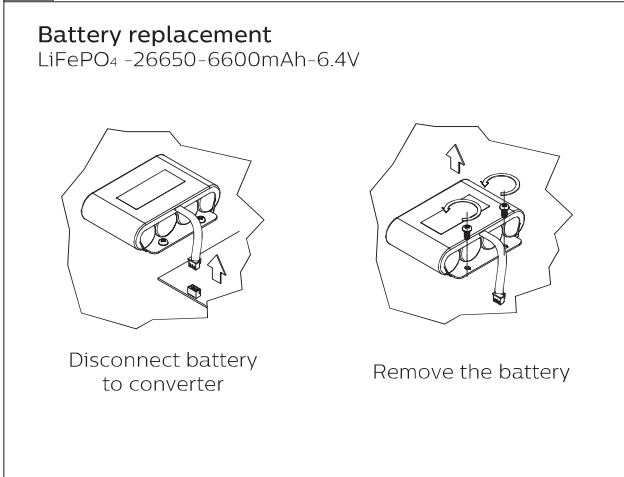
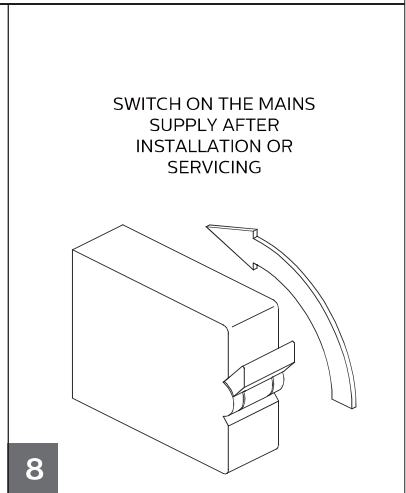
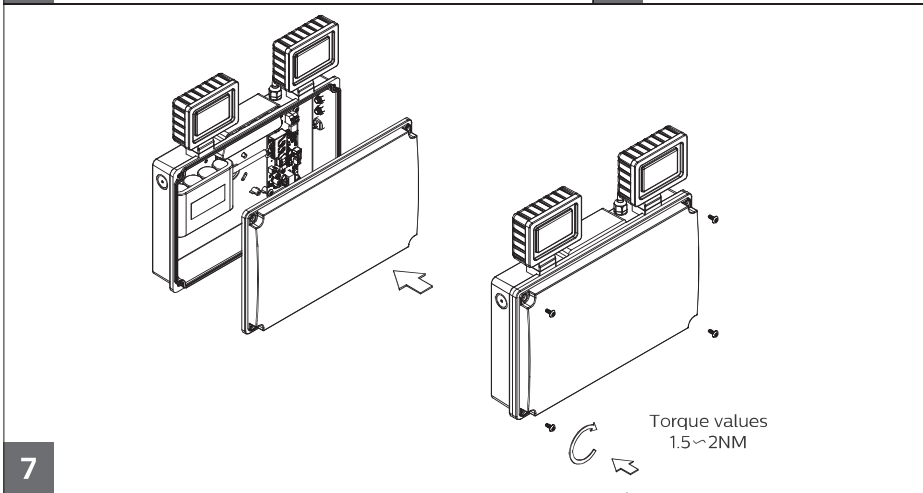
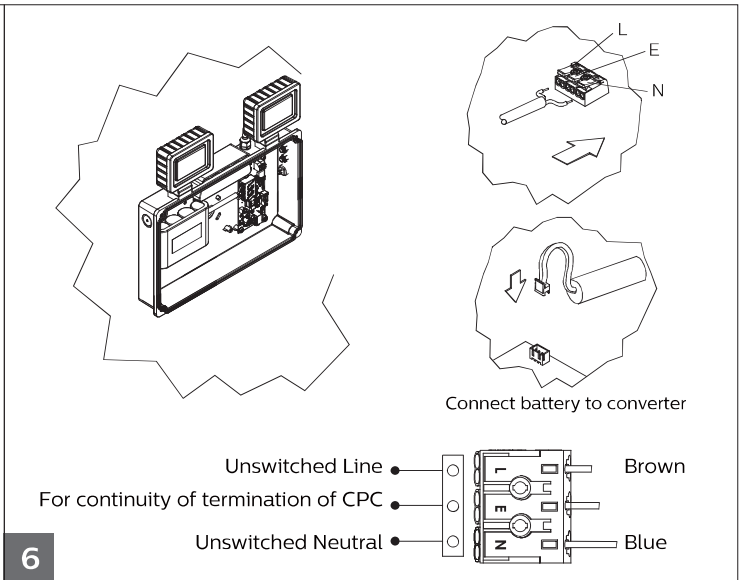
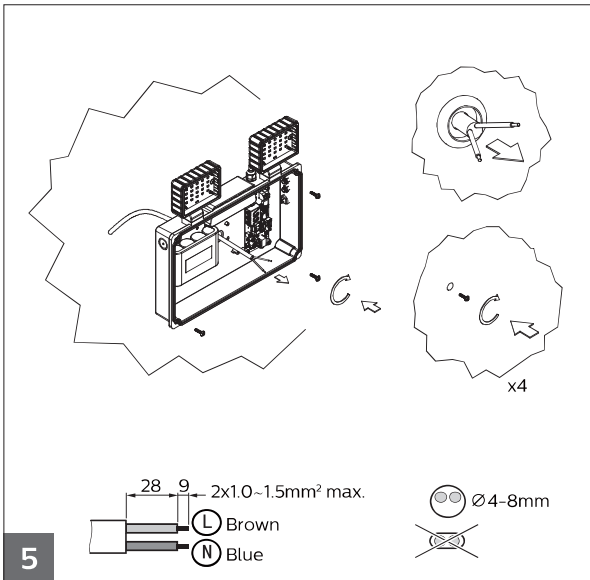

Spacing Data (1 lux)

Mounting Height (m)	Diagram 1	Diagram 2	Diagram 3	Diagram 4	Diagram 5
2.50	5.78	13.60	13.69	13.43	5.51
3.00	6.70	15.81	15.89	15.57	6.38
3.50	7.15	16.96	16.98	16.59	6.78
4.00	7.55	17.99	17.95	17.49	7.13



1. For indoor use only.
2. The luminaire complies with IEC60598-1IEC 60598-2-22.
The luminaire must be installed by a qualified electrician and wired in accordance with the latest IEE Electrical regulations or the national requirements.
3. Turn off the power supply before checking, installation, maintenance or moving.
4. Do not switch on before complete installation.
5. Batteries shall only be replaced by the manufacturer or his service agent or a similar qualified person.
6. Batteries should be replaced when the luminaire no longer meets the 3 hours duration performance.
7. Product mains surge immunity is 0.5/1KV (diff. / comm. mode). To prevent excessive currents and voltages from damaging the device, make sure that the power supply input is equipped with additional protection devices such as surge protectors. For any questions regarding the product's surge protection, please consult the manufacturer's professional.



Please inform yourself about the local waste disposal, separation and collection system for electrical and electronic products and packaging. Please act according to your local rules and do not dispose your old product and packaging with your normal household waste. The correct disposal of the packaging, your product and/or batteries will help prevent potential negative consequences for the environment and human health. Batteries should be disposed separately from the municipal waste stream via designated collection facilities. When disposing a product that contains non-user replaceable batteries, the non-user replaceable batteries shall be removed by a professional.

Testing Record

Product: _____

Location: _____

Installation Date: _____

Month	Functional/Duration	Year 1	Year 2	Year 3	Year 4	Year 5
1						
2						
3						
4						
5						
6						
7						
8						
9						
10						
11						
12						